

DM4315/4315EC Gimbal Motor

49mm gimbal motor, without and with encoder case

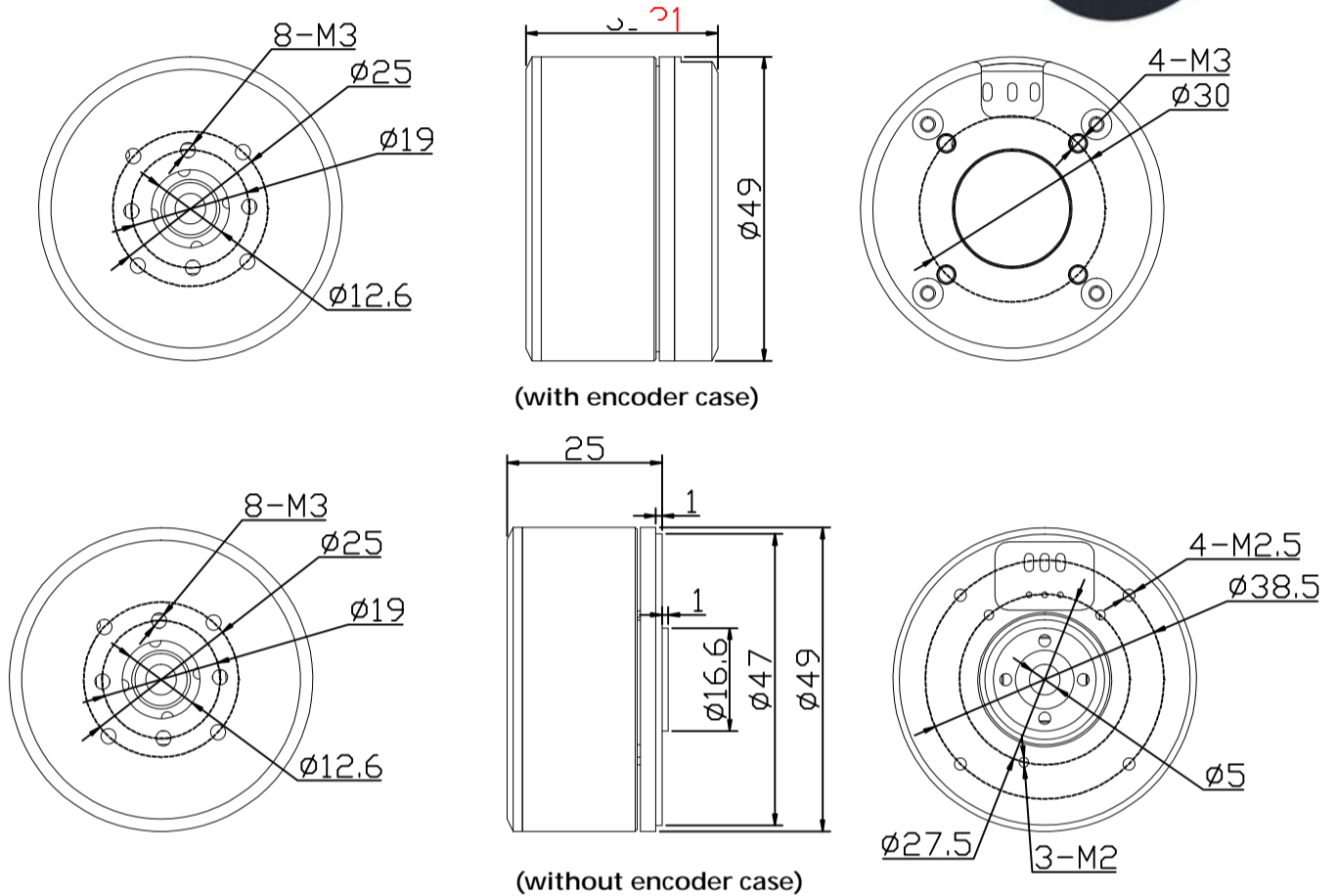

Dimension



Specification

Motor Data	Unit	DM4315/4315EC
1 Nominal voltage	V	24
2 Nominal current	A	0.59
3 Nominal torque	N.m	0.28
4 Nominal speed	rpm	238
5 Max speed	rpm	660
6 Stall torque	N.m	0.42
7 Stall current	A	0.9
8 Winding turns of motor	T	60
9 Phase to phase resistance	Ω	15.2
10 Phase to phase inductance	mH	6.56
11 Speed constant	rpm/V	23
12 Torque constant	Nm/A	0.47
13 Rotor inertia	gcm ²	268
14 Number of pole pairs		14
15 Weight	g	161/179.2
16 Working temperature	°C	-20/80
17 Max demagnetize temperature	°C	120
18 Encoder type		AS5048A/AS5600