

DDM8015 Gimbal Servo Motor

Gimbal motor with driver inside.

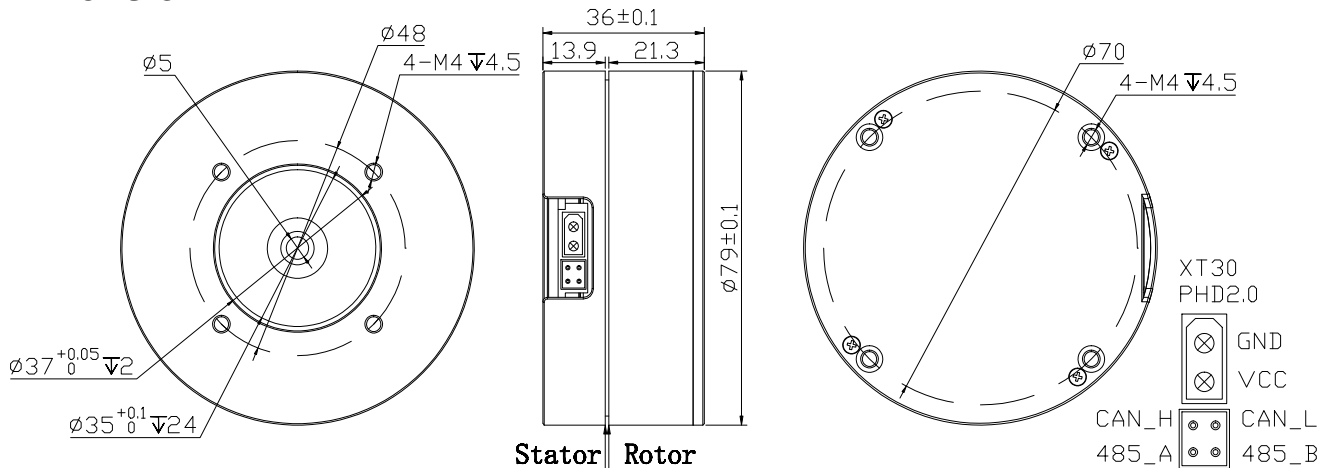

Dimension



Specification

Motor Data	Unit	Type:DDM8015
1 Nominal voltage	V	24
2. Voltage range	V	12~40
3 Nominal current	A	2.9
4. Nominal Power	W	69.6
5 Nominal torque	N.m	1.2
6 Nominal speed	rpm	354
7 Max speed	rpm	516
8 Peak torque	N.m	3.7
9 Peak current	A	16
10 Speed constant	rpm/V	21.5
11 Torque constant	Nm/A	0.41
12 Number of pole pairs		21
13 Phase to phase resistance	Ω	1
14 Phase to phase inductance	mH	0.63
15 Communication		RS485/CAN
16 Encoder type		Single-turn absolute
17 Resolution	bit	14
18 Weight	g	418
19 Working temperature	$^{\circ}\text{C}$	-20/80